

Adjust the Positive Air Flow

Positive air helps keep contaminants out of the printhead. Adjust the setting at the positive air needle valve, located on the solenoid bank (refer to Figure 8-16).

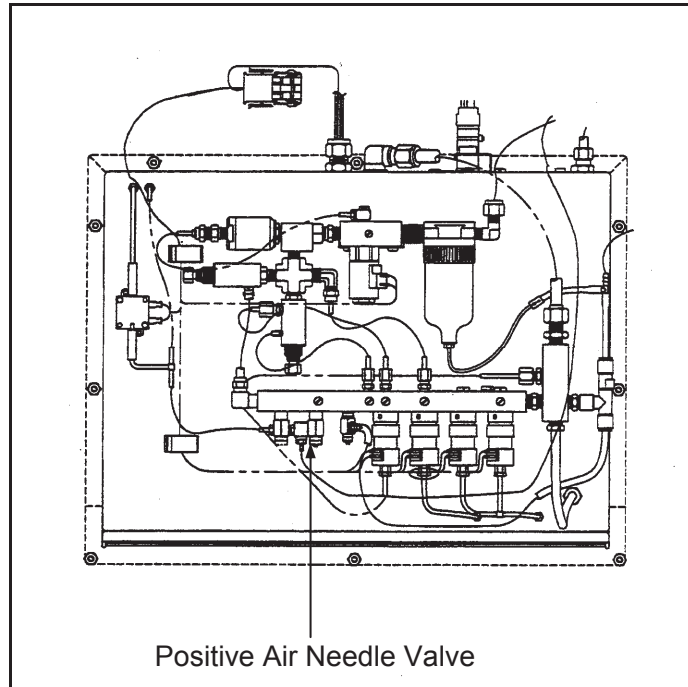

Figure 8-16. Adjusting the Positive Air Needle Valve

Use a screwdriver and a flow meter (VIDEOJET[®] P/N 356230) for this adjustment. The air flow is measured at the printhead with the ink On.

1. Hold the flow meter against the printhead faceplate (refer to Figure 8-17).
2. Adjust the needle valve to 1.5 +/- 0.5 SCFH measured at the printhead. The flow meter must be held vertical to get an accurate reading

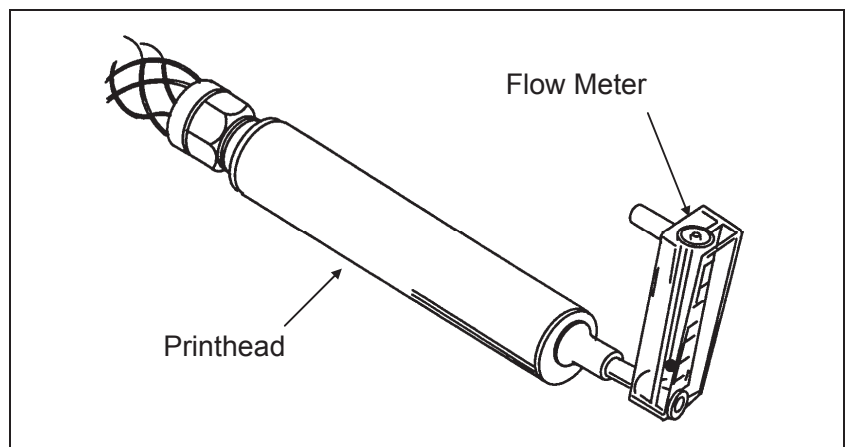

Figure 8-17. Air Flow Meter Attached to the Printhead